



Expansion module

EM 171

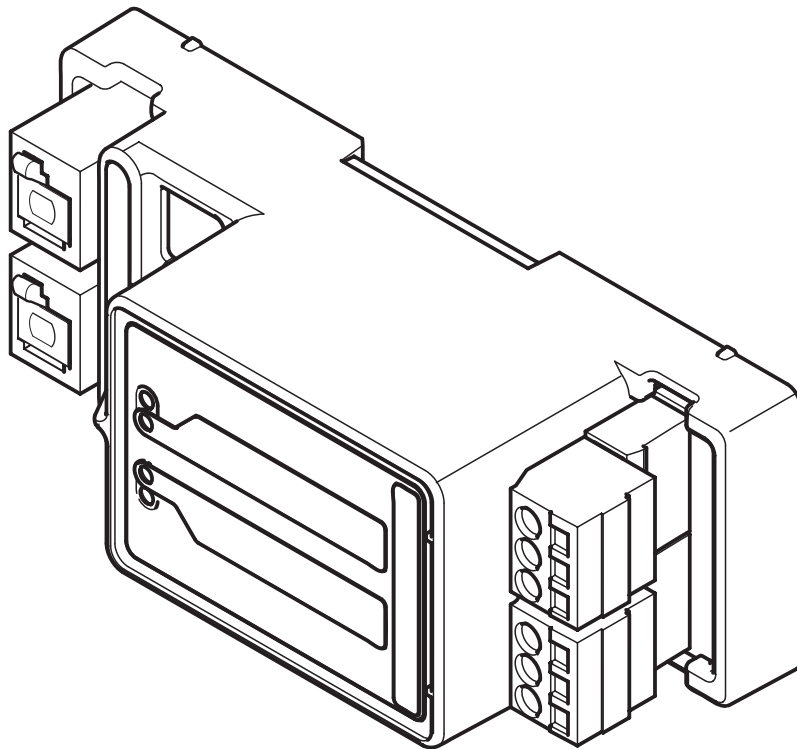

Table of Contents

1.	General safety advice	3
1.1	Correct use	3
1.2	Target group	3
1.3	Warranty	3
2.	Scope of delivery	4
3.	Dimensions	4
4.	Installation	4
4.1	Install the expansion module	4
4.2	Expansion module wiring	5
5.	Commissioning	6
6.	Programming	6
6.1	Comfort 260 – 380	6
6.2	Control vario	8
7.	Care	11

DANGER!

IMPORTANT SAFETY INSTRUCTIONS:

ATTENTION! IT IS VITALLY IMPORTANT FOR THE SAFETY OF PERSONS THAT YOU FOLLOW ALL THE INSTRUCTIONS. KEEP THESE INSTRUCTIONS IN A SAFE PLACE.

IMPORTANT INSTRUCTIONS FOR SAFE INSTALLATION:

ATTENTION! SERIOUS INJURIES CAN BE CAUSED IF THE EQUIPMENT IS NOT INSTALLED CORRECTLY – BE SURE TO FOLLOW ALL THE INSTALLATION INSTRUCTIONS.

Regarding this document

- Original instruction manual.
- Part of the product.
- Read these instructions carefully before use and keep them in a safe place for future reference.
- Protected by copyright.
- No part of this manual may be reproduced without our prior approval.
- Subject to alterations in the interest of technical progress.
- All dimensions are given in millimetres.
- The drawings are not true to scale.

Meaning of symbols

DANGER!

Safety notice indicating a danger that will directly result in death or severe injury.

WARNING!

Safety notice indicating a danger that could result in death or severe injury.

CAUTION!

Safety notice indicating a danger that could result in slight or moderate injuries.

NOTICE

Safety notice indicating a danger that could result in damage to property or in irreparable damage to the product.

CHECK

Reference to a check that needs to be carried out.

REFERENCE

Reference to separate documents that must be observed.

- Instruction requiring action
- List, itemisation
- Reference to other sections of this document
-  Factory settings

1. General safety advice

DANGER!

Risk of death with a failure to observe the documentation!

- Observe all safety information in this document.

1.1 Correct use

- The expansion module expands the Control vario control unit and the control unit for the garage door drive Comfort 260 – 380.

The following applies to the product EM 171:

- Operation is only permissible in dry rooms.
- The product is intended for private application areas.

1.2 Target group

- Installation, connection, commissioning and maintenance: qualified, trained specialist personnel.
- Operation, inspection and maintenance: operator of the gate system.

Requirements to be met by qualified and trained specialist staff:

- Knowledge of the general and specific safety and accident-prevention regulations.
- they have knowledge of the relevant electrical regulation,
- Training in the use and care of appropriate safety equipment.
- Adequate instruction and supervision by qualified electricians.
- The ability to recognise hazards that can be caused by electricity.
- Knowledge of the application of the following standards
 - EN 12635 ("Doors and gates - Installation and use"),
 - EN 12453 ("Safety in use of power operated doors - Requirements"),
 - EN 12445 ("Gates - Safety in use of power operated gates - Test methods").
 - EN 13241-1 ("Gates - Product standard - Part 1: Products without fire resistance or smoke control characteristics")

Requirements to be met by the operator of the gate system:

- knowledge and safekeeping of the instruction manual.
- Safe and proper keeping of the inspection logbook.
- Knowledge of general safety and accident-prevention regulations.
- Instruction of all persons who use the door system.
- Ensure that the door system is serviced and maintained periodically by qualified and trained professionals.

Special requirements apply to the following users:

- Children aged eight and above.
- Persons with reduced physical, sensory or mental capabilities.
- Persons with a lack of experience and knowledge.

These users are only authorised to operate the device.

Special requirements:

- The users must be supervised.
- The users must have been briefed on how to use the device.
- The users must understand the dangers involved in handling the device.
- Children are not allowed to play with the device.

1.3 Warranty

The product is manufactured according to the directives and standards mentioned in the Declaration of Incorporation.

The product has left the factory in perfect condition with regard to safety.

In the following cases, the manufacturer accepts no liability for damages. The guarantee on the product and accessory parts is voided with:

- A failure to observe these operating instructions.
- Misuse and improper handling.
- The assignment of unqualified personnel.
- Modifications or changes to the product.
- The use of spare parts that have not been produced or approved by the manufacturer.

Batteries, accumulators, fuses and bulbs are excluded from warranty.

Further safety information can be found in the relevant respective sections of the document.

→ "4. Installation"

→ "7. Care"

2. Scope of delivery

The product is supplied in a range of versions. On the basis of the table and scope of supply, check which version you have.

Country-specific deviations are possible.

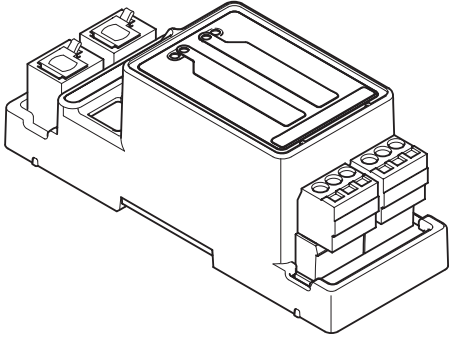
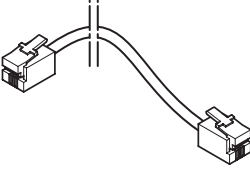
Pos.		
1		1x
2		1x

3. Dimensions

3 / 1

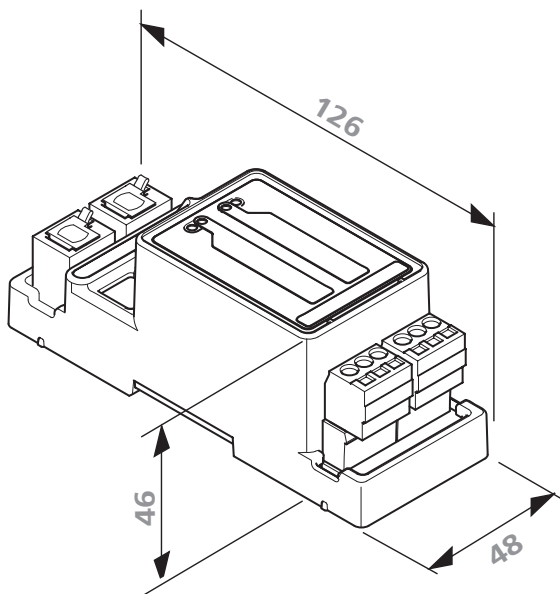

4. Installation

! DANGER!

Risk of fatal injuries due to electric shocks!

- It is vital that the drive system is disconnected from the power supply before any wiring work. Ensure that the electricity supply remains disconnected throughout any cabling work.
- Adhere to the local protection regulations.
- Lay the electricity supply cables and control cables; these **MuST** be laid separately.
The controls voltage is 24 v DC.

4.1 Install the expansion module

4.1 / 1

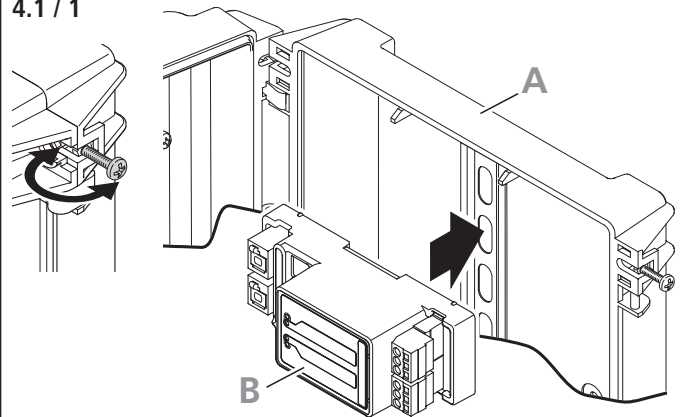

- Install the expansion module (B) in the expansion housing type 4 / type 5 (A).

4.2 Expansion module wiring

4.2.1 Overview of module connections

4.2.1 / 1

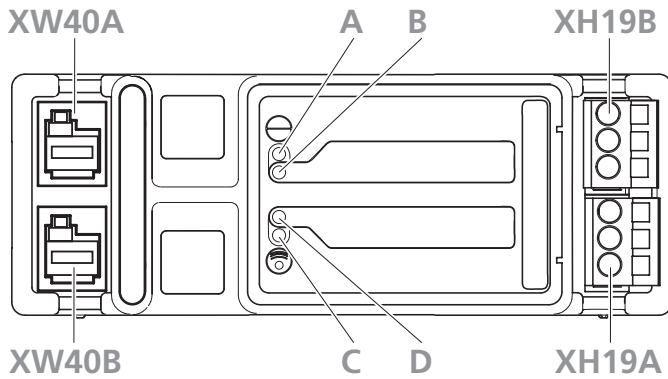

A	Operating display Illuminated Flashing Flashing quickly	operation cable break diagnostic mode
B	Display output XH19B	
C	Display manual transmitter actuated	
D	Display output XH19A	
XW40A	Connection of further module / drive / control	
XW40B	Connection of further module	
XH19A	Connection of potential-free relay contact	
XH19B	Connection of potential-free relay contact	

4.2.2 Connecting the module

Connecting the operating control and a further module

NOTICE

Possible malfunction of the motor unit!

To guarantee the correct function, only the Marantec bus system may be connected (MS-Bus).

4.2.2 / 1

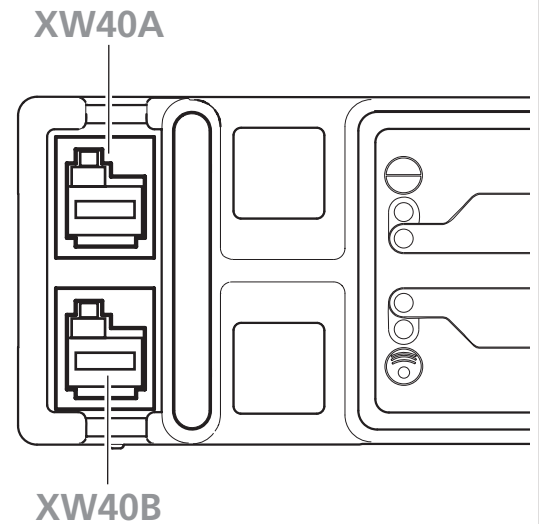

- Connect the Control vario control unit to the XW40A connection socket.
- Connect the Comfort 260–380 to the XW40A connection socket.
- If necessary, connect further modules to the XW40B connection socket.

NOTICE

Possible damage to the circuit board!

To avoid damage to the circuit board, the contact load (max. 230 V / 5 A) must be observed.

Connecting the signal light (XH19A)

4.2.2 / 2

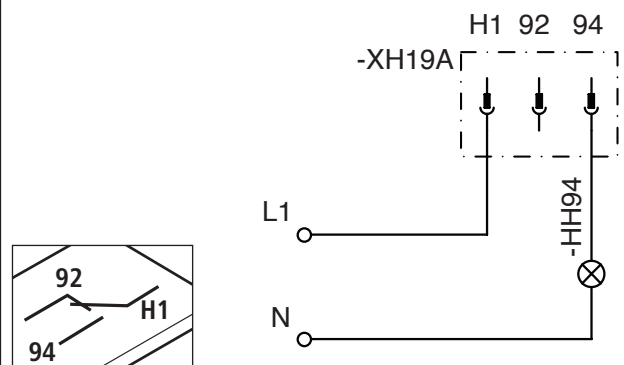

HH94	Customer's signal light
XH19A	Connection of signal equipment

Connecting the signal light (XH19B)

4.2.2 / 3

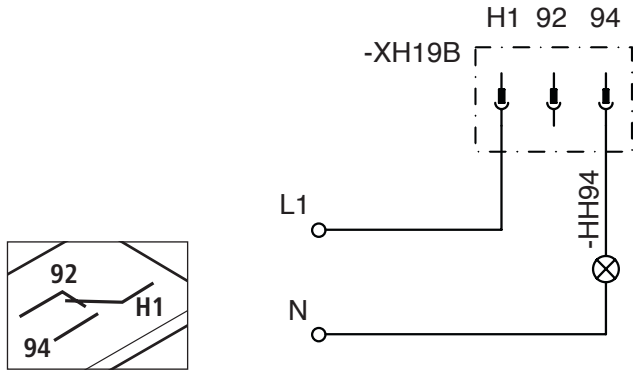

HH94	Customer's signal light
XH19B	Connection of signal equipment

5. Commissioning

5 / 1

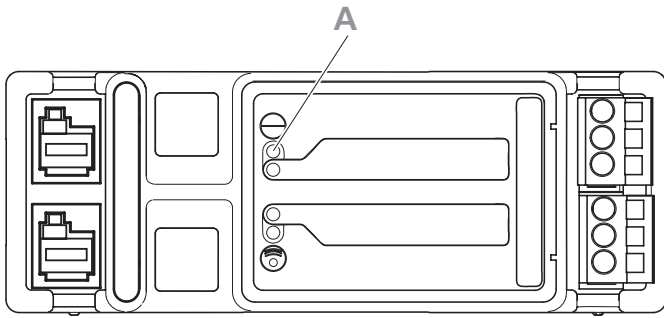

After the control unit has been connected, the display (A) flashes slowly.

- Perform a reset of the MS Bus modules:
 - Control vario (level 1 / menu 8 / G8),
 - Comfort 260 – 380 (level 1 / menu 8 / parameter 7)

The control unit requires approx. 30 seconds to detect connected modules.

The module reset is ended automatically.

The display (A) lights up.

- Set the desired functions:
 - Level 1 / menu 5 + 6

6. Programming

6.1 Comfort 260 – 380

Level 1 – Basic functions

Menu 5 – Relay output 1 - XH19A - (only with MS-BUS)

1	Relay off or set through MDS
2	Signal light → "Level 3, Menu 7 - Signal light"
3	Gate position OPEN
4	Gate position CLOSED
5	Intermediate position OPEN
6	Intermediate position CLOSED
7	Drive system starts (wipe pulse 1 second)
8	Fault
9	Lighting → "Level 5, Menu 4 - Lighting time"
10	Locking release (drive system running)
11	Maintenance indication
12	Gate running OPEN
13	Gate running CLOSED
14	Radio remote control (relay switches for the duration of the pulse)
15	Lock release (drive system starts / wipe pulse 3 seconds)
16	Anti-opening mechanism

Menu 6 – Relay output 2 - XH19B - (only with MS-BUS)

1	Relay off or set through MDS
2	Signal light → "Level 3, Menu 7 - Signal light"
3	Gate position OPEN
4	Gate position CLOSED
5	Intermediate position OPEN
6	Intermediate position CLOSED
7	Drive system starts (wipe pulse 1 second)
8	Fault
9	Lighting → "Level 5, Menu 4 - Lighting time"
10	Locking release (drive system running)
11	Maintenance indication
12	Gate running OPEN
13	Gate running CLOSED
14	Radio remote control (relay switches for the duration of the pulse)
15	Lock release (drive system starts (wipe pulse 3 seconds)
16	Anti-opening mechanism

Level 1 – Basic functions

Menu 8 – RESET

The drive system can be reset to the factory settings. After a reset of the control or replacement of the control box, all desired individual settings must be input again.

1	No reset
2	 Reset control (Connected modules (bus modules, remote control) must be reset separately)
3	Reset remote control (telegrams are deleted)
4	Reset expansion automatic closing → "Level 3 - Automatic closing"
5	Reset only expanded drive functions (apart from gate position OPEN/CLOSE and remote control pulse)
6	Reset safety elements (photocell / hold circuit)
7	Reset bus modules (connected bus modules are taught)

Level 3 – Automatic closing

The following menus and functions are only accessible for qualified, trained specialist personnel.

Menu 7 – Signal light

1	 Gate movement / warning: flashing Gate standstill: Off (energy saving)
2	Gate movement / warning: illuminated Gate standstill: Off (energy saving)
3	Gate movement / warning: flashing Gate standstill: flashing
4	Gate movement / warning: illuminated Gate standstill: illuminated
5	Gate movement / warning: flashing Gate standstill: illuminated
6	Gate movement / warning: illuminated Gate standstill: flashing

Level 4 – Radio programming

Menu 8 – Drive lighting ON / OFF

Parameter display flashing -> Press manual transmitter button -> Manual transmitter display also flashes -> The function has been taught.

The parameter "radio remote control" must not be programmed.

→ "Level 1, Menu 5 - Relay output 1 - XH19A"

→ "Level 1, Menu 6 - Relay output 2 - XH19B"

Level 5 – Special functions

Programming the special functions is dependent on the connection XB03.

Menu 4 – Lighting time

2 – 250 seconds.

 3.0 (180 seconds)

6.2 Control vario

Level 1 – basic functions

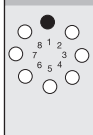
	1	2	3	4	5	6	7	8	9	10	11	12	13	14	15	16
--	---	---	---	---	---	---	---	---	---	----	----	----	----	----	----	----

Menu 5: Relay output 1 - XH19A - (only with MS-BUS)

	A5	B5	C5	D5	E5	F5	G5	H5	I5	J5	K5	L5	M5	N5	O5	P5
--	----	----	----	----	----	----	----	----	----	----	----	----	----	----	----	----



Menu 6: Relay output 2 - XH19B - (only with MS-BUS)

	A6	B6	C6	D6	E6	F6	G6	H6	I6	J6	K6	L6	M6	N6	O6	P6
--	----	----	----	----	----	----	----	----	----	----	----	----	----	----	----	----

Menu 8: RESET

	A8	B8	C8	D8	E8	F8	G8	-	-	-	-	-	-	-	-	-
--	----	----	----	----	----	----	----	---	---	---	---	---	---	---	---	---

Menu 5 and 6: Relay output 1, 2 and expansion

Stage	Function (only with optional signal light relay)	Explanation / note	 REFERENCE
A5 / A6	 Relay off or set through MDS	MDS	-
B5 / B6	Signal light	Function	Level 3 / menu 7
C5 / C6	Gate position OPEN	-	-
D5 / D6	Gate position CLOSED	-	-
E5 / E6	Intermediate position OPEN	-	-
F5 / F6	Intermediate position CLOSED	-	-
G5 / G6	Drive system starts	Wipe pulse 1 second	-
H5 / H6	Fault	-	-
I5 / I6	Lighting	Lighting time	Level 5 / menu 4
J5 / J6	Locking release	Drive system running	-
K5 / K6	Maintenance indication	-	-
L5 / L6	Gate running OPEN	-	-
M5 / M6	Gate running CLOSED	-	-
N5 / N6	Radio remote control	Relay switches for the duration of the pulse	-
O5 / O6	Release lock	Drive system starts / wipe pulse 3 seconds	-
P5 / P6	Anti-opening mechanism	-	-

Menu 8: Reset

NOTICE

After a reset, all parameters are reset to the factory settings.





In order to guarantee faultless operation of the control:

- all desired functions must be reprogrammed,
- the remote control must be taught,
- the drive system must be driven into the gate position OPEN and CLOSED once.

Stage	Function	Explanation / note
A8	 no reset	unchanged
B8	Reset control *	Factory settings
C8	Reset remote control	Telegrams are deleted
D8	Reset expansion automatic closing	–
E8	Reset only expanded drive functions *	apart from gate position OPEN/CLOSE and remote control pulse
F8	Reset safety elements *	Photocell
G8	Reset bus modules	connected bus modules are taught

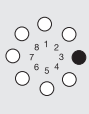
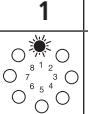
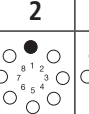
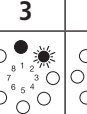
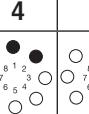
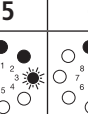
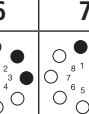
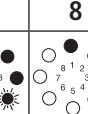
* All connected and functional safety elements are redetected after the reset.

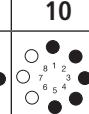
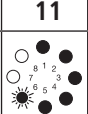
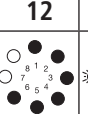
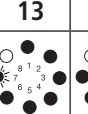

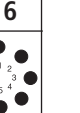
Level 3 – automatic closing

	1	2	3	4	5	6	7	8	9	10	11	12	13	14	15	16
																

Menu 7: Signal light

	A7	B7	C7	D7	E7	F7	–	–	–	–	–	–	–	–	–	–
																

Menu 7: Signal light

Stage	Gate movement / warning	Gate standstill
A7	 flashing	 Off (energy saving)
B7	illuminated	Off (energy saving)
C7	flashing	flashing
D7	illuminated	illuminated
E7	flashing	illuminated
F7	illuminated	flashing

Level 4 – radio programming

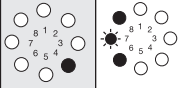

Menu 8: EWM relay output (level 1, menu 5/I5, menu 6/I6)



LED 7 flashes slowly -> press manual transmitter button -> LED 7 flashes quickly

Level 5 – special function

	1	2	3	4	5	6	7	8	9	10	11	12	13	14	15	16

Menu 4: Lighting time (in seconds)

	2	5	10	15	20	25	30	35	40	50	80	100	120	150	180	255

7. Care

DANGER!

Risk of fatal injuries due to electric shocks!

- It is vital that you disconnect the operator system from the power supply before cleaning. Take measures to ensure that the power supply remains disconnected for the duration of the cleaning operation.

NOTICE

Damage resulting from incorrect operation!

When cleaning the drive, never use:

direct water jets, high pressure cleaners, acids or alkaline solutions.

- Clean the outside of the housing using a damp, soft cloth that does not shed fibres.

If particularly dirty, the housing can be cleaned using a mild detergent.

Type plate

Typ (A)	_____
Rev (B)	_____
Art. No. (C)	_____
Prod. No. (D)	_____

